

Design Evaluation of Sheet Metal Joints for Dimensional Integrity

D. Ceglarek

Department of Mechanical Engineering and Applied Mechanics

J. Shi

Department of Industrial and Operations Engineering,
The University of Michigan,
Ann Arbor, MI 48109-2136

The design of joints between parts is one of the most critical issues in the design of sheet metal assemblies. This paper presents a new part-to-part joint design evaluation index developed for dimensional control of sheet metal assemblies. The proposed index provides a new analytical tool to address the dimensional capabilities of an assembly process in the early product design stage. It covers the three basic types of joints, which encompass the whole domain of joints used in sheet metal assembly. The part-to-part interactions for each type of joint are studied, and an analytical model is provided. Two evaluation indices, (1) product joint design evaluation and (2) critical part determination, are developed. The developed methodology is demonstrated using two industrial design examples of sport-utility automotive bodies.

1 Introduction

1.1 Problem Description. Geometrical accuracy is one of the most important quality factors in sheet metal assembly such as an automotive body. Variations in geometrical accuracy can stem from both the design and manufacture of a product. In fact, dimensional variation is introduced into virtually every design when the design is manufactured (Parkinson et al., 1993). Because some manufacturing induced variation is inevitable, it is important to minimize the level of inherent dimensional variation caused by the product design. Moreover, product design will affect the level of variation introduced by the manufacturing process. Many of the problems associated with geometrical accuracy occur because the capability of the manufacturing process is not considered when designing the product. Therefore, early and accurate evaluations of inherent design variation can be critical factors determining the final dimensional variation of an assembled vehicle.

In general, dimensional variation is caused by (1) part-to-part interference, (2) lack of part location stability, and (3) part variation. Interference is caused by the types of joints between various parts, whereas locating instability (part misalignment) is caused by the types and positions of locators in the assembly stations. These two problems, interferences and misalignments, were identified by Boeing as the two most frequent causes of engineering changes (Shalon et al., 1992).

The third cause of dimensional variation, part variation, is caused by variation inherent in the stamping process. The dimensional variation of an assembly caused by part variation and part misalignment can be reduced but cannot be completely eliminated. However, well designed part-to-part joints can make an assembly robust to these sources of variation. Joints can reduce or even eliminate the propagation of geometric variation from a variety of sources between components. Propagation of variation depends on the joint geometry and direction of the error source. Because some directions are less critical than the others (specified by the GD&T), they can be used to "absorb" sources of variation. Thus, the design of part-to-part joint interactions is critical for the dimensional integrity of the final product.

These final products are often complex assemblies having large numbers of parts with multiple interactions. Designing

joints for a complex product requires analyzing an enormous amount of engineering information and considering a large number of design constraints. In addition, high-performance modern products demand that precision and complexity be satisfied simultaneously. Currently, the design and manufacture of motor vehicles provides the clearest evidence of this trend towards precision combined with complexity (Ayres, 1988). The modern automotive body, shown in Fig. 1, is built out of 250 sheet metal parts, assembled in 55–75 assembly stations with 1,700–2,500 fixturing locators, and joined by 4,100 welding spots (Ceglarek, 1994). Despite this level of complexity, best-in-class manufacturers have achieved a dimensional integrity of 6-sigma variation within 2 mm for all critical measurement points located on the automotive body (Ceglarek and Shi, 1995). Ceglarek and Shi (1995) concluded that the 2 mm level of 6-sigma variation¹ for a studied vehicle represents the inherent level of design capabilities. Further reduction of dimensional variation depends on the improvement of product/process design, especially the design of joints for sheet metal parts (Ceglarek et al., 1993).

1.2 Literature Review. Although product and process design impact one another, product design has traditionally been separated from process design. Lately, manufacturers have begun to investigate ways to simultaneously evaluate product designs and manufacturing processes in an attempt to eliminate downstream problems of manufacturing, assembly, maintenance, etc. (Gadh, 1993). One vivid example of process/product development integration is the cohesive car body styling, body engineering, body stamping die design, and die manufacture at Toyota (Whitney, 1993). The problem with this program—and most of the design rules and guidelines associated with manufacturability analysis—is that they require experience-based knowledge (El-Gizawy et al., 1990).

Structured Methodologies. Another factor impeding design improvements is that predictive information from analytical methods used to improve design is based on the structured methodologies such as design for assembly/manufacture (DFA/DFM), quality function deployment (QFD), and functional analysis. These methods have significantly extended the analytical design tools for product development. However, there is a

¹Contributed by the Manufacturing Engineering Division for publication in the JOURNAL OF MANUFACTURING SCIENCE AND ENGINEERING. Manuscript received Jan. 1995; revised May 1997. Associate Technical Editor: J. W. Sutherland.

¹A parameter describing dimensional variation of the automotive body can be defined as 6-sigma standard deviation calculated for each measurement point of the product with a given sample size. This parameter can be used for fast-tracking of the product variation level. For more details, see Ceglarek and Shi (1995).

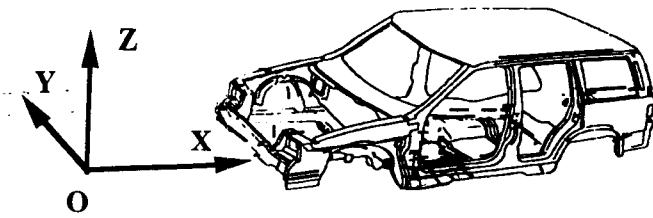

Fig. 1 Example of an automotive body (body-in-white)

danger that they may oversimplify product objectives and may become a substitute for in-depth, global thinking (Barkan and Hinckley, 1993) that is often very important during the selection and evaluation of design constraints.

To overcome these limitations, a number of researchers investigated different modeling-based approaches to enhance design methodology.

Modeling-based Approaches. Thurston (1991) proposed an approach based on multiattribute utility analysis, which iteratively evaluates design alternatives early in the design process. This method allows the creation of a design evaluation function based on several critical steps. Gadh (1993) stated that any assembly can be described by a design function reflecting geometrical relations. However, the function depends very strongly on the type of design and can be built in many different ways (Boothroyd, 1987; Taguchi et al., 1989; Wood and Antonsson, 1989; Medoff et al., 1989; Miyakawa et al., 1990; Yannoulakis et al., 1991).

Geometrical Constraint Propagation Methods. The alternative approaches that investigated geometrical constraint propagation/constraint management during design process were proposed by Serrano (1987) and Kramer (1990). Serrano (1987) developed a methodology for management of the geometrical constraints throughout the evolving design, based on the graph theoretical approach. Constraint networks for a given design are represented as directed graphs, where nodes represent parameters and arcs represent constraint relationships. The developed method, based on the network topology, allows evaluation of constraint networks and the detection of over- and under-constrained systems of constraints, as well as identification and correction of redundant and conflicting constraints. Kramer (1990) presented a method of finding configurations of a set of rigid bodies to satisfy a set of geometric constraints using a symbolic reasoning method called degree of freedom analysis. This method finds the configurations (position and orientation) of a set of rigid bodies that satisfy a set of geometric constraints. By generating a sequence of actions that incrementally satisfy each system constraint, the system's remaining degree of freedom is monotonically decreased. This method allows analysis of the sequence of actions during the assembly process to determine globally permissible locations of assembled bodies' points. The constraint propagation-based methods are extremely valuable for assembly task specification/planning using the constraint satisfaction problem (CSP) approach over finite and infinite domains. It is conceptually straightforward to formulate assembly planning in terms of CSP, but the choice of constraint

representation and the order in which the constraints are applied is nontrivial if a computationally tractable system design is to be achieved (Liu and Poppestone, 1990). Liu and Poppestone (1990) presented the method which reduces the complexity caused by interactions between a pair of interleaving constraints (kinematic and spatial occupancy constraints) by using the symmetries of assembly components. They adopted the results of group theory as being the standard mathematical theory of symmetry. Additionally, they observed that assembly of three dimensional rigid bodies can be described by possible assembly configurations that are represented in terms of mating features configurations.

The constraint propagation approaches study the feasibility of a given assembly sequence under the assumption that the geometry of all assembled components is known. They do not analyze sensitivity of the assembly to propagation of dimensional variation. Therefore, it is difficult to apply these methods during the upstream design stage where detailed component geometries are unknown. Additionally, these methods do not allow for comparison and benchmarking of different designs with regard to their sensitivity to dimensional variation of components and tooling.

Assemblability and Tolerance Propagation Methods. The other methods of assembly design enhancement are based on the studies of the assemblability through analysis of the tolerance propagation (Bjorke, 1989; Turner and Wozny, 1990; Whitney and Gilbert, 1993; Lee and Yi, 1995ab). Bjorke (1989) presented a method of tolerance analysis and propagation based on a defined relationship between components in an assembly represented by so-called fundamental equations. He developed a systematic procedure for tolerance analysis in which he defined: (1) classification of the different links between components, (2) determination of fundamental equations for different links, (3) component distributions for different machining processes, and (4) the resultant sum dimension of the assembly. Bjorke (1989) proposed using beta distribution for a single component as more appropriate for many manufacturing conditions where there are small lot sizes, truncated distributions, or skewed distributions. Turner and Wozny (1990) presented a mathematical theory of tolerances in which tolerance specifications are interpreted as constraints on a normed vector space of model variations (M-space). This expands Requicha's (1983) representation by defining an additional model of certain types of part variations. Thus, rather than defining a single abstract model of a nominal part, a variational class of part instances is defined. They claim that if the model variables are properly chosen, they may be taken as a basis for a normed vector space of model variations (M-space). Every point in the M-space for an assembly corresponds to a particular instance of the assembly.

Whitney and Gilbert (1993) proposed representing various types of tolerances (position, orientation, size) in a kinematic parameter space (represented as a homogeneous matrix transform). They showed that different types of tolerance can be represented by kinematic parameters such as rotations and translations. Based on the developed representation for nominal poses of features, Whitney and Gilbert (1993) represent tolerances as differential pose variations that calculate the tolerance

Nomenclature

$C_{i,j}$ = j -th component in the i -th layer	\mathbf{R} = component interaction matrix	$\delta_c(i)$ = components evaluation index of joint designs
$r^p(i,j)$ = index describing joint geometry	$S_{i,j}$ = i -th assembly station in the j -th layer of the hierarchical groups	$\delta_{c_{max}}(i)$ = index of the component i with the strongest interactions for a given assembly
$r(i,j)$ = index describing direct interaction	α = the angle between the defined direction of interaction and the mating features of two components (Fig. 5)	δ_p = product evaluation index of joint designs
c_g = gap capability index		

propagations based on the maximum deviation. They optimize tolerance parameters by using ellipsoids, which are approximations of the simulated tolerance volumes. To optimize the boundary limits of the ellipsoid, the Monte-Carlo method was used with chi-square optimization. Their method focuses on the product-related variation, which they divided into two groups: (1) individual component variations and (2) mating variations. Mating variations result from a combination of the component variations and other factors influencing relative part position. This method was further expanded by Lee and Yi (1995ab). Lee and Yi (1995ab) presented assemblability analysis based on statistical analysis of tolerance propagation. This method uses the developed graph representation for subassemblies, called a feature graph, as well as the representation of tolerances using kinematic parameters developed by Whitney and Gilbert (1993). These two representations are used for statistical analysis of the tolerance and clearance propagations of serial and parallel assembly chains. The authors suggested that this method can be applied to assembly planning for generation of more realistic assembly sequences with an assemblability measurement. The assemblability measurement, as defined by Lee and Yi (1995a), measures the probability of the successful assembly of two mating subassemblies, using pose tolerance and clearance propagation. The work done by Whitney and Gilbert (1993) and Lee and Yi (1995ab) analyzes the assembly sequences through the feasibility (probability) of obtaining a correct assembly, rather than analysis of the assembly sensitivity to part and tooling dimensional variation. Additionally, they do not allow comparison of different designs through the uniformly defined index.

1.3 The Proposed Method. All the aforementioned papers reflect the importance of quantitative measures of manufacturability in product design evaluation.

However, there is no available function/index to evaluate part-to-part joint design interactions for sheet metal assemblies. The interaction here is understood as a behavior by which one part can affect another in respect to dimensional position. The presented paper tries to fill this gap by presenting a quantitative evaluation index for part joint design with respect to the dimensional integrity of the product. The proposed index identifies potential dimensional failures during the assembly process, and provides a quantitative measure for design comparisons between different products. In addition, the proposed index is easy to understand and implement.

The paper is divided into five sections. Section 2 presents an approach for modeling joint geometry and design gaps. Section 3 describes a methodology for creating a design evaluation index based on the modeled joint geometry and design gaps. In Section 4, two examples illustrate the proposed design evaluation index. Finally, in Section 5 we discuss the implications of this study and summarize the results.

2 Modeling of Interactions Between Components (Parts)

The level of part-to-part interactions is very important for robustness of the design to dimensional variation. Part-to-part

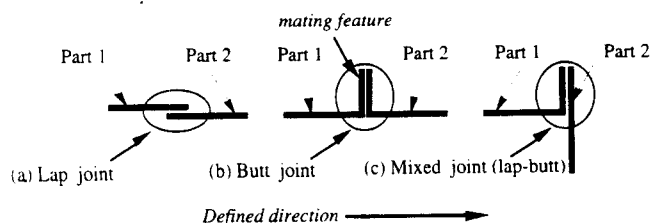

Fig. 2 Cross-sectional views of joint geometries

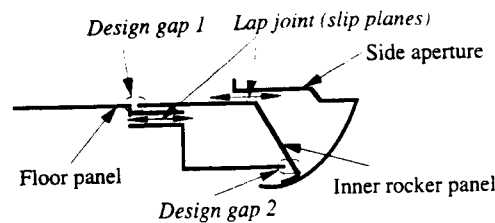

Fig. 3 Design 1: an example of lap joints and a design gap

interactions can be characterized as the design "easiness" of transferring variation between different parts (through its mating features) in the case of occurrence of some dimensional discrepancies causing dimensional variability. These dimensional discrepancies can have different sources such as: part variability, fixturing, geometry of part, part-to-part joint geometry (mating features), and so on.

The objective of this section is to develop an analytical model for part-to-part (component-to-component) interactions. The developed model should allow for (1) comparative analysis of different designs, and (2) decomposition of designed assemblies into sub-designs with clear representations of their interdependencies. These criteria are based on the premise that understanding the design-related interactions between different components requires decomposing the total interactions into simple ones, such as the interactions between adjacent components (those components physically next to each other). The joint design evaluation index is developed based on the geometrically defined interactions between adjacent components. The modeling of these interactions is based on the joint geometry. The salient characteristics of the geometrical interactions between components proposed in this paper can be classified as follows:

- (1) Direct interactions—interactions between any adjacent components
- (2) Indirect interactions—interactions between any non-adjacent components

The explanations and modeling of the different interactions are presented below. Section 2.1 presents the geometrical modeling of joints between adjacent components (direct interactions). Section 2.2 describes interactions between non-adjacent components (indirect interactions).

2.1 Direct Interactions Between Mating Features of Components.

The modeling of interactions between mating features of components is based on the modeling of different types of joints used in sheet metal assembly: (1) lap joints, (2) butt joints, and (3) mixed joints (lap-butt) (Fig. 2). These three types of joints define the whole domain of joints used in sheet metal assembly. Two important concepts—mating features and defined directions—are used to describe joints (Fig. 2):

- (1) Mating feature: any part of the component geometry whose presence is relevant to a component's joint function, e.g., the flange, extrusion, and so on
- (2) Defined direction: the important axis of an analyzed joint, usually defined by design specifications

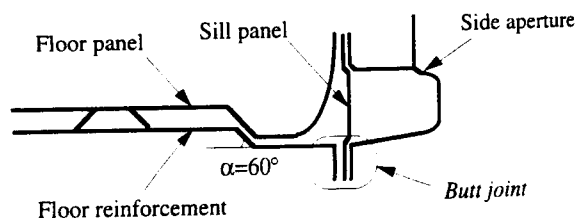

Fig. 4 Design 2: an example of butt joints

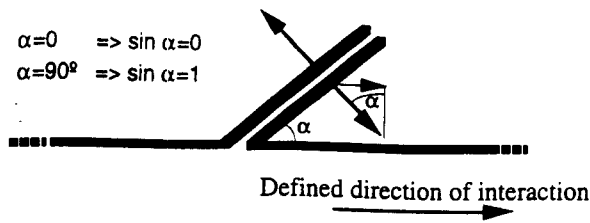

Fig. 5 A model of the interaction between mating features

In this paper, it is assumed that there is only one type of interaction between any two components characterized by one type of joint.

The important characteristic of these joints is that each of them has a defined direction with the highest part-to-part interaction. For example, the lap joint does not introduce any constraint in the defined direction of interaction, and the butt joint does create a constraint in the defined direction. Figures 3 and 4 provide two examples of the lap (slip planes) and butt joints respectively, used in an automotive underbody/aperture design. Additionally, Fig. 3 shows an example of a design gap between the floor panel and the inner rocker panel. Including design gaps as an interaction between mating features is important because design gaps can absorb the variation of a component or of a component's location.

(1) Modeling of Joints

(a) Modeling of the Lap and Butt Joints:

The joint between part i and part j described as a lap or butt joint can be modeled by coefficient $r^p(i, j)$ defined as:

$$r^p(i, j) = \sin \alpha \quad (1)$$

where the angle α is defined as the angle between the defined direction and the mating features of two components (Fig. 5). The different values of angle α define different joints between mating features as follows:

1. $\alpha = 0^\circ (180^\circ) \Rightarrow$ slip planes (2)

2. $\alpha = 90^\circ (270^\circ) \Rightarrow$ butt joint (3)

(b) Modeling of the Design Gap Between Two Components:

The design gap is modeled by the introduced gap capability index c_g . The proposed index describes the probability of the interference occurrence between two components based on their dimensional variation and nominal positions. The gap capability index is defined as:

$$c_g = \frac{2A}{B_i + B_j} = A \quad (4)$$

where B_i and B_j describe the areas underneath the statistical distributions for the process capability and tolerances of component i and component j respectively; and A is the overlap between these two distributions shown in Fig. 6 as a shaded area.

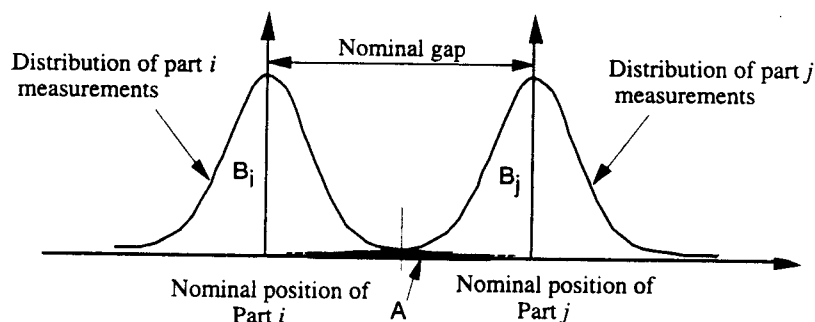

Fig. 6 A model of design gap

The area under the probability density function is equal to one, therefore, the area of $(B_i + B_j) = 2$ (Siddall, 1983). This area represents the probability that interference occurs between parts i and j . The smaller the index c_g , the smaller the interaction between components. The different values of the gap capability index c_g also define different levels of interactions between mating features equal to the probability level of interference occurrence between parts. It can be interpreted as follows:

1. $c_g \rightarrow 0 \Rightarrow$ no contact between components i and component j (5)

2. $c_g = 1 \Rightarrow$ "full contact": component i and component j touch each other (6)

(2) Modeling of Interaction Between the Mating Features of Two Components

The interactions in a given direction between the mating features of two components i and j can be modeled by index $r(i, j)$, defined as:

$$r(i, j) = c_g r^p(i, j) = c_g \sin \alpha \quad (7)$$

The index $r(i, j)$ illustrates the level of interaction between the mating features of two components while simultaneously including the manufacturing process capabilities (for example, design gaps). It allows analysis of potential interferences during the design stage. The index can be interpreted as a cumulative result of the combined factors: (1) design gap (c_g), and (2) joint geometry. The interactions described by coefficient r are called direct interactions. The direct interaction can be defined as follows:

Definition 1: The direct interaction of two components i and j is defined as an interaction between their mating features in the case when these components are adjacent to each other.

It can be stated that direct interaction between any two components is independent of other interactions. It is worth observing that the commutative property holds for the defined interactions in a given direction, i.e.,

$$r(i, j) = r(j, i) \quad (8)$$

2.2 Indirect Interactions Between Components. The previous section defines the direct interaction as an interaction between mating features of two adjacent components. A complex assembly usually includes a large number of interacting components, which are not adjacent to each other. The notion of indirect interactions is introduced here to explain this type of situation.

The indirect interactions integrate the product design with the process sequence represented by hierarchical groups of product and process (Ceglarek et al., 1994). Figure 7 shows an example of the hierarchical groups for the left-hand aperture of the automotive body. It considers a design scenario involving

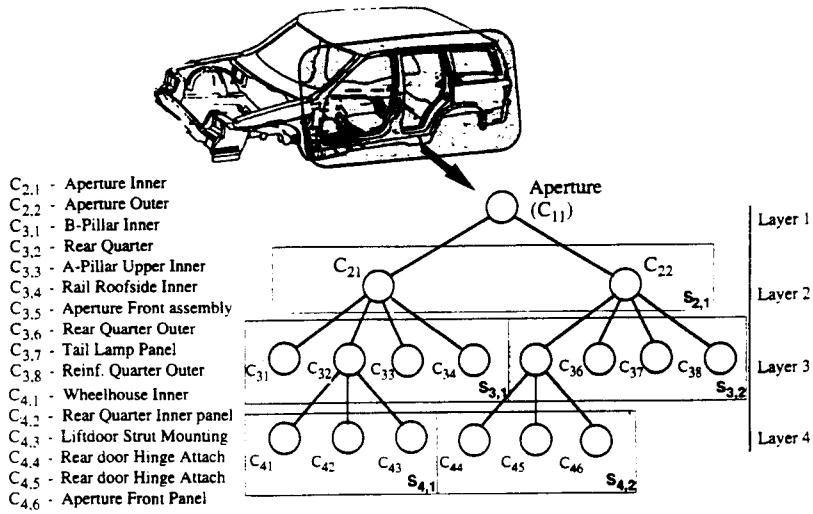

Fig. 7 Example of an automotive body product/process design scheme represented as the hierarchical groups of product/process

12 components ($C_{i,j}$) assembled within four layers by five assembly stations ($S_{i,j}$). The hierarchical groups describe two types of assembly sequences. One type shows the sequence of stations used in the assembly process (for example, $S_{4,1} \rightarrow S_{3,1} \rightarrow S_{2,1}$ (Fig. 7)). The other level shows the sequence of components entering a single station (for example, components $C_{3,1} \rightarrow C_{4,2} \rightarrow C_{4,3}$ for station $S_{4,1}$). These two types are represented by vertical and horizontal links among the components. The vertical connections among the modules represent the sequence of stations in the assembly process. The horizontal layout of the components for a given station describes the sequence of the components entering a single assembly station (Shi et al., 1994).

Definition 2: The interaction of the mating features of two components $C_{i,j}$ and $C_{k,l}$ is called an indirect interaction when these components are not adjacent to each other.

As an example, the hierarchical groups can be used to identify interactions for each component. Figure 8 provides an example of indirect interactions for component $C_{4,1}$ using the hierarchical groups.

Any two non-adjacent components $C_{i,j}$ and $C_{k,l}$ are connected through the direct interactions of their subassemblies A and B on some higher level (layer in the hierarchical group of product/process), such that $C_{i,j} \subset A$ and $C_{k,l} \subset B$, where relation “ \subset ” is a “subassembly of.” It can be expressed by the following definition:

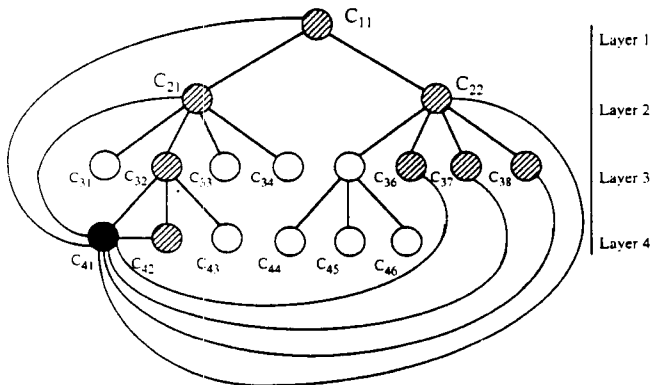

Fig. 8 An example of interactions for component $C_{4,1}$ in the aperture design

Definition 3: Indirect interactions between components $C_{i,j}$ and $C_{k,l}$ are defined as direct interactions of two components, called critical components $C_{i,j}$ and $C_{k,l}$ ($C_{i,j} \neq C_{k,l}$), which are assembled in one assembly station $S_{i,m}$, such that $C_{i,j}$ and $C_{k,l}$ are adjacent to each other, and:

1. $C_{i,j} \subset C_{i,j}$ and $C_{k,l} \subset C_{k,l}$; and
2. $C_{i,j} \not\subset C_{k,l}$ and $C_{k,l} \not\subset C_{i,j}$.

Figure 9 shows an example of the indirect interaction between components $C_{4,1}$ and $C_{3,7}$. The indirect interaction between components $C_{4,1}$ and $C_{3,7}$ is defined as a direct interaction $r(C_{2,1}, C_{2,2})$ between components $C_{2,1}$ ($C_{4,1} \subset C_{2,1}$ and $C_{3,7} \not\subset C_{2,1}$) and $C_{2,2}$ ($C_{3,7} \subset C_{2,2}$ and $C_{4,1} \not\subset C_{2,2}$) assembled in station $S_{2,1}$. Therefore, $r(C_{4,1}, C_{3,7}) = r(C_{2,1}, C_{2,2})$. The notion of indirect interactions extends the notion of direct interactions and will be applied when analyzing the impact of the product design on the process variability.

3 Evaluation Index of Component Joints Design

Component Interaction Matrix. The direct and indirect interactions can be represented as a component interaction matrix R :

$$R = \begin{bmatrix} r_{1,1} & r_{1,2} & \dots & r_{1,n} \\ r_{2,1} & r_{2,2} & \dots & r_{2,n} \\ \dots & \dots & \dots & \dots \\ r_{n,1} & r_{n,2} & \dots & r_{n,n} \end{bmatrix} \quad (9)$$

where $r_{i,j}$ represents a direct or indirect interaction between components i and j respectively. The sequence of components in the matrix R can be an arbitrary but consistent set from the hierarchical groups chart. For example, the sequence of components in the matrix R : $\{1, 2, \dots, n\}$ is equivalent to the following sequence from the hierarchical groups $\{C_{1,1}, C_{2,1}, C_{2,2}, \dots, C_{3,1}, C_{3,2}, \dots, C_{4,1}, C_{4,2}, \dots\}$ that can be shown as:

$$\begin{matrix} & & & 1 & 2 & \dots & \dots \\ & & & C_{1,1} & C_{2,1} & \dots & \dots \\ 1 & C_{1,1} & & r_{1,1} & r_{1,2} & \dots & r_{1,n} \\ 2 & C_{2,1} & & r_{2,1} & r_{2,2} & \dots & r_{2,n} \\ \vdots & \vdots & & \dots & \dots & \dots & \dots \\ \vdots & \vdots & & r_{n,1} & r_{n,2} & \dots & r_{n,n} \end{matrix}$$

Product Evaluation Index of Joint Designs. The joint design evaluation index for product dimensional integrity is based on the developed interactions between different components. It

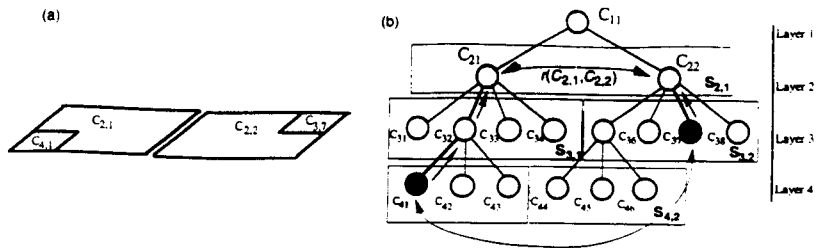

Fig. 9 Indirect interactions between components

is assumed that the stronger the interaction between components, the stronger the transmitted dimensional error through the design. Evaluation of joint design is based on the defined index δ_p :

$$\delta_p = \frac{1}{n(n-1) - m} [(\sum_{i=1}^n \sum_{j=1}^n |r_{i,j}|) - n] \cdot 100\% \quad (10)$$

where $r_{i,j}$ is the direct or indirect interaction between the i -th and j -th components, and $|r_{i,j}|$ represents an absolute value of " $r_{i,j}$ "; n is the number of components for a given design; and m represents the number of not existing interactions, e.g., the connection between an assembly and its subassembly (for example, components $C_{2,1}$, $C_{4,1}$, in Fig. 9 do not have defined interactions). The index δ_p represents an average level of interactions for each component, defined by joint geometry and expressed by the index r . The smaller the index δ_p , the weaker the interactions between the components in the analyzed design.

Components Evaluation Index of Joint Designs. The evaluation of component-to-component interactions for complex designs might require a separate analysis of a specific component. Additionally, corrections and modifications of the design can require a detailed design analysis of a single component with the largest interactions. The proposed index $\delta_c(i)$ allows evaluations of the interactions for a single i -th component:

$$\delta_c(i) = \frac{1}{(n-1) - m} [(\sum_{j=1}^n |r_{i,j}|) - 1] \cdot 100\% \quad (11)$$

The component with the strongest interactions can be estimated as the component with the biggest coefficient $\delta_c(i)$:

$$\delta_{cmax}(i) = \max_{i=1,n} \{\delta_c(i)\} \quad (12)$$

Remarks. The developed indices δ_p and $\delta_c(i)$ have two purposes:

1. The product evaluation index of joint designs δ_p allows comparisons between different designs for benchmarking pur-

poses. The value of δ_p describes the average interaction level in the analyzed design. The δ_p is defined in a range from 0% to 100%, where 0% and 100% represent interactions equivalent to lap and butt joints respectively. The smaller the δ_p index, the better the design, i.e., the less dimensional variation that will be transferred between components.

2. The component evaluation index of part joints design $\delta_c(i)$ allows comparisons between different components of the analyzed design. The value of $\delta_c(i)$ describes an average interaction for a given component i of the analyzed design. The $\delta_c(i)$ is defined in the same range and with the same interpretation as the product evaluation index δ_p . The $\delta_c(i)$ index allows designers to identify the strongest interactions within a design and, if needed, to re-design joints or re-assign tolerances for critical dimensions.

4 Examples

Two studies of sport-utility vehicles are presented to illustrate the interactions occurring in two different designs. Both vehicles were designed during the same time period. The first example illustrates the interactions for an underbody designed with slip planes, and the second example shows an underbody designed with butt joints (Figs. 3 and 4).

Evaluation of Design 1—Underbody-Aperture Interaction. Figure 3 shows a design sketch of an underbody/aperture cross-section. The hierarchical groups of product/process for this example are presented in Fig. 10. From Fig. 10, it can be concluded that the presented design is:

1. Built of six major components (Table 1); and
2. Assembled in three assembly stations (Table 2).

The defined direction for this design is the inboard/outboard axis (Fig. 10). From the design point of view, the inboard/outboard interaction between the underbody and aperture determines the geometry of the whole automotive body—sensitivity to the matchboxing effect, subassembly distortion, and so on. A description of all critical joints is shown in Fig. 3. The compo-

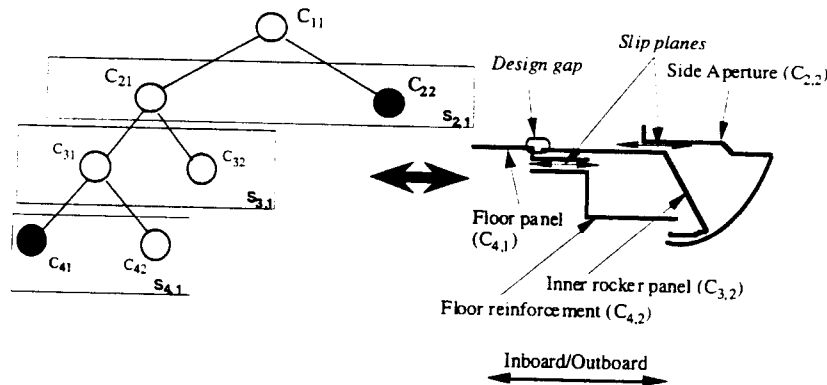

Fig. 10 Design 1: aperture-underbody

Table 1 Design 1: list of components

Sequence in Interaction Matrix	Code	Component Name
1	C _{2,1}	- underbody
2	C _{2,2}	- aperture
3	C _{3,1}	- floor assembly
4	C _{3,2}	- inner rocker panel
5	C _{4,1}	- floor panel
6	C _{4,2}	- floor reinforcement

Table 2 Design 1: list of assembly stations

Code	Station Name	Assembled Components
S _{2,1}	Framing	C _{2,1} , C _{2,2}
S _{3,1}	Sill Assembly	C _{3,1} , C _{3,2}
S _{4,1}	Underbody Marriage	C _{4,1} , C _{4,2}

nent interaction matrix [Eq. (9)] for this design can be presented as:

$$\mathbf{R} = \begin{bmatrix} r_{1,1} & r_{1,2} & \dots & r_{1,6} \\ r_{2,1} & r_{2,2} & \dots & r_{2,6} \\ \dots & \dots & \dots & \dots \\ r_{6,1} & r_{6,2} & \dots & r_{6,6} \end{bmatrix}$$

$$= \begin{bmatrix} 1 & 0 & \emptyset & \emptyset & \emptyset & \emptyset \\ 0 & 1 & 0 & 0 & 0 & 0 \\ \emptyset & 0 & 1 & c_g & \emptyset & \emptyset \\ \emptyset & 0 & c_g & 1 & c_g & c_g \\ \emptyset & 0 & \emptyset & c_g & 1 & 0 \\ \emptyset & 0 & \emptyset & c_g & 0 & 1 \end{bmatrix} \quad (13)$$

where \emptyset means that a joint does not exist, such as the connection between an assembly and its subassembly. For example, element $r_{3,4}$ describes the interaction between component 3 and 4 as shown in Table 1. From Fig. 10, the joint between the floor assembly and inner rocker panel is a butt joint ($\alpha = 90$ deg; $r(i, j) = \sin \alpha = 1$) with a design gap equal to c_g .

The product evaluation index of this component joint design can be calculated from Eq. (10), and based on the information included in Eq. (13), as:

$$\delta_p = 0.28 c_g \cdot 100\% \leq 28\% \quad (14)$$

where c_g (≤ 1 from Eq. (6)) is a design gap assigned between components $C_{3,1}$ (floor assembly) and $C_{3,2}$ (inner rocker panel). The most critical component is estimated, based on Eq. (12), as:

$$\delta_{c,max}(4) = 0.75 c_g \cdot 100\% \quad (15)$$

The most critical component in this example is assembly (#4

or $C_{3,2}$). The dimensional integrity of this design depends mainly on the design gap between the floor assembly and inner rocker panel. Correctly estimating this design gap, including the assembly process capability, can make this design completely interaction-free.

Evaluation of Design 2—Underbody-Aperture Interaction. Figure 4 shows the design sketch of another underbody/aperture cross-section. The hierarchical groups of product/process for this example are presented in Fig. 11. From Fig. 11, it can be concluded that the presented design is (1) built of six major subassemblies (Table 3), and (2) assembled in three assembly stations (Table 2).

The two designs shown are very similar regarding the sequence of the assembly process and the number of components. On the other hand, their joint designs are completely different, which significantly affects the dimensional integrity of the final product.

The defined direction for this design is the same as in the first example, i.e., the inboard/outboard axis. The description of all critical joints is shown in Fig. 4. The component interaction matrix [Eq. (9)] for this design can be presented as:

$$\mathbf{R} = \begin{bmatrix} r_{1,1} & r_{1,2} & \dots & r_{1,6} \\ r_{2,1} & r_{2,2} & \dots & r_{2,6} \\ \dots & \dots & \dots & \dots \\ r_{6,1} & r_{6,2} & \dots & r_{6,6} \end{bmatrix}$$

$$= \begin{bmatrix} 1 & 1 & \emptyset & \emptyset & \emptyset & \emptyset \\ 1 & 1 & 1 & 1 & 1 & 1 \\ \emptyset & 1 & 1 & 1 & \emptyset & \emptyset \\ \emptyset & 0 & 1 & 1 & 1 & 1 \\ \emptyset & 1 & \emptyset & 1 & 1 & 0.87 \\ \emptyset & 1 & \emptyset & 1 & 0.87 & 1 \end{bmatrix} \quad (16)$$

where \emptyset means that a joint does not exist as defined in Eq. (13). For example, element $r_{3,6}$ describes interactions between component 5 ($C_{4,1}$ —floor panel) and 6 ($C_{4,2}$ —floor reinforce-

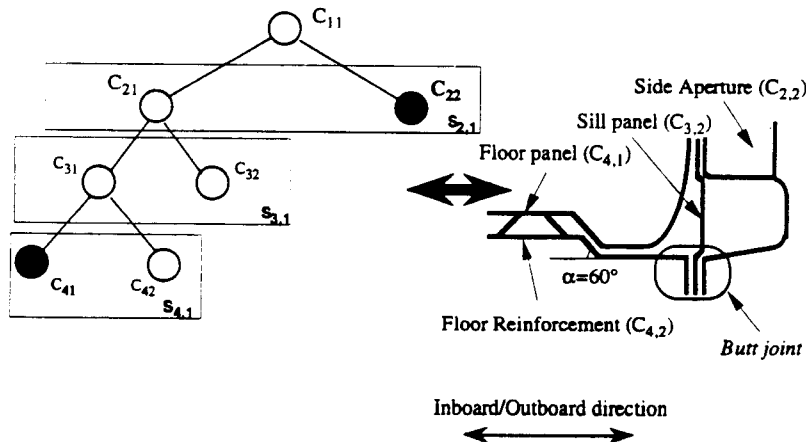

Fig. 11 Design 2: aperture-underbody

Table 3 Design 2: list of components

Sequence in Interaction Matrix	Code	Component Name
1	C _{2,1}	- underbody
2	C _{2,2}	- aperture
3	C _{3,1}	- floor assembly
4	C _{3,2}	- sill assembly
5	C _{4,1}	- floor panel
6	C _{4,2}	- floor reinforcement

ment). As shown in Fig. 11, the joint between the floor panel and floor reinforcement is a modified "butt" joint ($\alpha = 60$ deg: $r_{s,6}^2 = \sin \alpha = 0.87$).

The product evaluation index of this component-to-component joint design can be calculated from Eq. (10), based on the information included in Eq. (16), as:

$$\delta_p = 93\% \quad (17)$$

The most critical component is estimated, based on Eq. (12), as:

$$\delta_{c,max}(2) = 100\% \quad (18)$$

The most critical component in this example is aperture (#2 or C_{2,2}). The variation of the aperture panel assembly will directly contribute to the variation in the inboard/outboard axis in station S_{2,1}. The design of this example shows strong interactions caused by product design. This design is "non-compensatory" in the sense of dimensional integrity. Any dimensional discrepancies of the side aperture or underbody will directly affect the aperture position and, in turn, the whole frame of the vehicle.

Comparison of Designs 1 and 2

(1) Product evaluation index δ_p

Table 4 shows the δ_p index for both designs. Design 2 shows much stronger interactions between components than Design 1. The correct assignment of the design gap (c_g) in Design 1 can completely eliminate interactions between components. The interactions in Design 2 are equivalent, on average, to a butt joint (93 percent). From this analysis, it can be concluded that Design 2 will have a much bigger dimensional variation than Design 1 even if all manufacturing-related problems are eliminated. Studies conducted in automotive body assembly facilities show that the inherent level of variation of Design 1 is 1.5–1.7 mm 6-sigma variation. On the other hand, the inherent level of variation of Design 2 is 2.2–2.4 mm 6-sigma variation.

(2) Components evaluation index $\delta_c(i)$

Table 5 lists the $\delta_c(i)$ index of all components for both Design 1 and 2. In Design 1, components 1 and 2 (underbody and aperture) are interaction-free. Thus, part variation will not be transferred or accumulated in the inboard/outboard axis, i.e., the product design is robust with respect to dimensional integrity. However, all components of Design 2 show very strong interac-

Table 4 Product evaluation index δ_p for Designs 1 and 2

	Design 1		Design 2
		If $c_g=0.05$	
δ_p [%]	$28c_g$	1.4	93

Table 5 Component evaluation index $\delta_c(i)$ for Designs 1 and 2

Components	Design 1		Design 2
		If $c_g=0.05$	
1	0	0	100
2	0	0	100
3	$50c_g$	2.5	100
4	$75c_g$	3.75	75
5	$33c_g$	1.65	95.67
6	$33c_g$	1.65	95.67

tions. Any part variation will be transferred or accumulated in the defined direction (inboard/outboard axis), and therefore, this design is not robust.

5 Summary and Conclusions

In sheet metal assembly, geometrical accuracy is one of the most important quality factors. Interference and misalignment between joined parts are the two largest causes of engineering changes. Therefore, the design of joints between parts is a critical issue in the design of sheet metal assemblies. Thoughtful joint design can make the whole design robust to sources of variation transferred from one part to the another.

This paper develops a part joint design evaluation index for dimensional control of sheet metal assemblies. The proposed index provides a new analytical tool to address the process dimensional capabilities in the early stages of product design. A major advantage of the proposed index is that it can be used as an analytical tool to analyze and benchmark different designs regarding their dimensional integrity, as well as point out the part most affected by strong interactions.

The part joint design evaluation index is defined in terms of three basic geometric interactions between components: lap joints, butt joints, and design gaps. This index allows modeling of the broad domain of different component-to-component interactions. Additionally, the design gap concept is also included in the developed index. It allows incorporation of the process capabilities during the product design stage.

The part joint design evaluation is presented as (1) a product joint evaluation index, which summarizes the average interaction for the whole product, and (2) a critical part determination index, which selects the parts of the design with the strongest interactions.

The proposed approach was implemented using two different sport-utility body designs in two different assembly facilities. The conclusions drawn from these examples using this approach were confirmed by studies of actual dimensional variation conducted in these two automotive body assembly facilities. Additionally, more extensive studies (Himbert and Ceglarek, 1996) were conducted by (1) comparing five different designs and their dimensional variation level, as well as by (2) analyzing the experimental results of the simplified sheet metal designs. Both studies confirmed relation between the proposed index and the level of dimensional variation. The results of these additional studies will be presented in a separate paper.

References

- Ayres, R. U., 1988, "Complexity, Reliability, and Design: Manufacturing Implications," *Manufacturing Review*, Vol. 1, No. 1, pp. 26–35.
- Barkan, P., and Hinckley, C. M., 1993, "The Benefits and Limitations of Structured Design Methodologies," *Manufacturing Review*, Vol. 6, No. 3, pp. 211–220.
- Bjorke, O., 1989, *Computer-Aided Tolerancing*, ASME Press, New York, 1989.
- Boothroyd, G., 1987, "Design for Assembly—The Key to Design for Manufacturing," *The International Journal of Advanced Manufacturing Technology*, Vol. 2, No. 3.

- Ceglarek, D., 1994, "Knowledge-Based Diagnosis for Automotive Body Assembly: Methodology and Implementation." Ph. D. Dissertation, University of Michigan, Ann Arbor.
- Ceglarek, D., and Shi, J., 1995, "Dimensional Variation Reduction for Automotive Body Assembly Manufacturing." *Manufacturing Review*, Vol. 8, No. 2, pp. 139-154.
- Ceglarek, D., Shi, J., and Wu, S. M., 1994, "A Knowledge-based Diagnosis Approach for the Launch of the Auto-Body Assembly Process." *ASME JOURNAL OF ENGINEERING FOR INDUSTRY*, Vol. 116, No. 4, pp. 491-499.
- Ceglarek, D., Shi, J., and Zhou, Z., 1993, "Variation Reduction for Body Assembly: Methodologies and Case Studies Analysis." Final Report for the Jeep Grand Cherokee Dimensional "2 mm" Program for Chrysler Corp., University of Michigan, Ann Arbor.
- El-Gizawy, A. S., Hwang, J.-Y., and Brewer, D. H., 1990, "A Strategy for Integrating Product and Process Design of Aerospace Components." *Manufacturing Review*, Vol. 3, No. 3, pp. 178-186.
- Gadh, R., 1993, "A Hybrid Approach to Intelligent Geometric Design Using Features-Based Design and Feature Recognition." *Proceedings of the 19th Annual ASME Design Automation Conference*, DE-Vol. 65-2, pp. 273-283.
- Himbert, M., and Ceglarek, D., 1996, "Managing Dimensional Variation in Automotive Body Assembly by Design Analysis." Technical Report, University of Michigan, Ann Arbor.
- Kramer, G. A., 1990, "Solving Geometric Constraint Systems." *Proceedings of the National Conference on AI*, pp. 708-714, Boston.
- Lee, S., and Yi, C., 1995a, "Statistical Measure of Assemblability under the Propagation of Tolerance and Clearances." *Proceedings of the 1995 IEEE International Symposium on Assembly and Task Planning*, pp. 94-99, Pittsburgh, PA.
- Lee, S., and Yi, C., 1995b, "Evaluation of Assemblability Based on Statistical Analysis of Tolerance Propagation." *Proceedings of the 1995 IEEE International Conference on Intelligent Robots and Systems*, v. 3, pp. 256-261.
- Liu, Y., and Poppestone, R. J., 1990, "Symmetry Constraint Inference in Assembly Planning." *Proceedings of the National Conference on AI*, pp. 1038-1044, Boston.
- Medoff, S. M., Register, M. S., and Swartwout, M. W., 1989, "A Framework for Design Verification and Evaluation Systems." *Artificial Intelligence for Engineering Design, Analysis and Manufacturing*, Vol. 3, No. 2, pp. 71-84.
- Miyakawa, S., Ohashi, T., and Iwata, M., 1990, "The Hitachi New Assemblability Evaluation Method (AEM)." *Transactions of NAMRI*, Vol. 18, pp. 352-359.
- Parkinson, A., Sorensen, C., and Pourhassan, N., 1993, "A General Approach for Robust Optimal Design." *ASME Journal of Mechanical Design*, Vol. 115, No. 1, pp. 74-80.
- Requicha, A. A. G., 1983, "Toward a Theory of Geometric Tolerancing." *The International Journal of Robotics Research*, Vol. 2, No. 4, pp. 45-60.
- Serrano, D., 1987, "Constraint Management in Conceptual Design." Ph.D. Dissertation, MIT, Boston.
- Shalon, D., Gossard, D., Ulrich, K., and Fitzpatrick, D., 1992, "Representing Geometric Variations in Complex Structural Assemblies on CAD Systems." *Proceedings of the 19th Annual ASME Advances in Design Automation Conference*, DE-Vol. 44-2, pp. 121-132.
- Shi, J., Hu, S. J., and Ceglarek, D., 1994, "Process Navigator for the Automobile Body Assembly Process." *Proceedings of the First S. M. Wu Symposium on Manufacturing Science*, Evanston IL, pp. 325-332.
- Siddall, J., 1983, *Probabilistic Engineering Design: Principles and Applications*, Marcel Dekker, New York.
- Taguchi, G., Elsayed, E., and Hsiang, T., 1989, *Quality Engineering in Production Systems*, McGraw-Hill.
- Thurston, D., 1991, "A Formal Method for Subjective Design Evaluation with Multiple Attributes." *Research in Engineering Design*, Vol. 3, pp. 105-122.
- Turner, J. U., and Wozny, M. J., 1990, "The M-Space Theory of Tolerances." *ASME Proc. of Advances in Design Automation*, 1990.
- Whitney, D. E., 1993, "Integrated Design and Manufacturing." *Manufacturing Review*, Vol. 6, No. 4, pp. 329-342.
- Whitney, D. E., and Gilbert, O. L., 1993, "Representation of Geometric Variations Using Matrix Transforms for Statistical Tolerance Analysis in Assemblies." *Proceedings of the 1993 IEEE International Conference on Robotics and Automation*, Vol. 2, pp. 314-321.
- Wood, K. L., and Antonsson, E. K., 1989, "Computations with Imprecise Parameters in Engineering Design: Background and Theory." *ASME Journal of Mechanical Design*, Vol. 111, pp. 616-625.
- Yannoulakis, N. J., Joshi, S. B., and Wysk, R. A., 1991, "A Manufacturability Evaluation and Improvement System." *Proceedings of the 3rd International ASME Design Theory and Methodology Conference*, DE-Vol. 31, pp. 217-226.

