

## Report on the 2014 Interior Renovations to the Mandela Park WaSH-UP Facility



Mollie Myers, Heather Ullery, Danielle Haley, Nathan  
George

December 12, 2014

Abstract: This report documents the renovations made to the Mandela Park WaSH-UP Facility in Langrug in 2014 and makes recommendations for future improvements. The document is designed to help future projects in the facility by sharing the physical changes made, explaining the purpose behind these renovations, and providing recommendations for future renovations to the facility. Furthermore, the information collected here can be utilized by others creating or renovating WaSH-UP facilities.

Authors: Mollie Myers, Nathan George, Danielle Haley, Heather Ullery

WPI Project Advisors: Scott Jiusto and Stephen McCauley

Series Editor: Scott Jiusto

Project Partners: Langrug Community, Community Organisation Resource Centre

Project Website: For much more on the project from which this report derives, please see <http://wp.wpi.edu/capetown/projects/p2014/wash-up-services/>.

CTPC Publication Date: December 2014

### ***About the WPI CTPC Community Resources Series***

Community Resources publications are designed to assist residents, community-based and non-profit organizations, local government, students, educators and others working toward sustainable community development in disadvantaged communities in South Africa and elsewhere.

Documents may be downloaded at <http://wp.wpi.edu/capetown/resource-library/>. If you have inquiries or would like permission to reproduce, republish, or substantially adapt the content of this document for other non-profit purposes, please contact us at [ctpc@wpi.edu](mailto:ctpc@wpi.edu).

The Cape Town Project Centre (CPTC) is part of the Worcester Polytechnic Institute (WPI) Global Projects Program offering WPI students project opportunities in two dozen centers around the world. Each year, about 26 CTPC third-year undergraduate students from our US university work closely in small groups with local Cape Town organizations and communities on issues posed by our local partners. This report is one of a number of project outcomes produced during two months of fieldwork in Cape Town. See the CTPC website for more information: <http://wp.wpi.edu/capetown>.

Copyright © WPI 2014

## Table of Contents

<b>Introduction</b> .....	<b>4</b>
<b>Library Bookshelf</b> .....	<b>4</b>
Purpose .....	4
Renovations .....	4
Future Recommendations .....	5
<b>Painting</b> .....	<b>5</b>
<b>Interior Color Change</b> .....	<b>5</b>
Purpose .....	5
Renovations .....	6
Future Recommendations .....	7
<b>Alphabet and Numbers beneath Sink</b> .....	<b>7</b>
Purpose .....	7
Renovations .....	7
Future Recommendations .....	7
<b>Washing Hands Sign above Sink</b> .....	<b>7</b>
Purpose .....	7
Renovations .....	8
Future Recommendations .....	8
<b>Posters</b> .....	<b>8</b>
Purpose .....	8
Renovations .....	8
Future Recommendations .....	9
<b>Recommendations for Future Renovations</b> .....	<b>10</b>
<b>Fencing</b> .....	<b>10</b>
<b>Storage Renovations</b> .....	<b>10</b>
<b>Sign</b> .....	<b>10</b>

## Introduction

A large part of establishing a social space in the Mandela Park facility dealt with renovations to the facility to make it more aesthetically pleasing and inviting. Particularly with the creation of the aftercare programme, we wanted the facility to be more welcoming and educational for children. As a result, we painted the interior with lots of bright colors and added educational elements like the alphabet and numbers being painted on the sinks. The aftercare and the library also needed storage space, so a small bookshelf was constructed to hold books and equipment. It was vital for the space to evolve further from a sanitation area to a dynamic environment that facilitates health, education, and wellbeing services. In order to do this, we added a clock and educational posters, some of which even had healthy tips and pictures of fruits. Additionally, we began a “wash your hands” mural on the wall above the sink. We hope this report serves to document our changes, suggest further improvements, and provide any information you may need about these physical changes to the facility.

## Library Bookshelf

### Purpose

The library bookshelf was constructed alongside the creation of the community library and aftercare programme to integrate social services into the facility. The shelves provide a space for the library books and the aftercare puzzles and toys. It also serves as a space for the library checkout book, as well as the aftercare binder and equipment sign-out binder.

### Renovations



The shelves are made in the form of a freestanding bookcase, located to the left of the sinks. The shelves were constructed of wood, found in the storage bungalow of the facility. The bookcase is approximately 122 cm tall, 73 cm wide, and 35 cm deep. There are three shelves and also enough space beneath the bottom shelf to place two plastic milk crates. Each shelf is held to the supporting sides with three screws on each side, spaced approximately equally apart. Before construction the shelves were painted blue with oil-based paint. After construction the outside edge of the shelves was painted red.

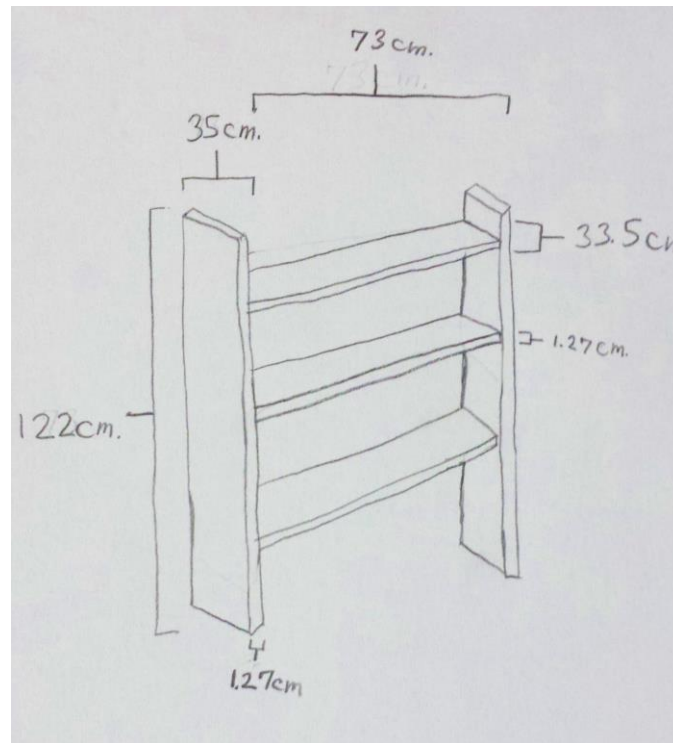

### Future Recommendations

The bookshelf currently is slightly crooked due to a combination of uneven flooring, nonparallel walls to work with, and slightly uneven pieces of recycled wood. Future projects should consider the slant of the wall that the bookshelf will lean against and the uneven floor to ensure the bookshelf has maximum stability. Additionally, the bookshelf is not very large, so future projects can create more shelves for storing a growing library and separate the aftercare toys into another area.

## Painting

### Interior Color Change

#### Purpose

In an effort to create a more engaging social space and brighten the atmosphere of the facility, the interior was redone with brightly colored paint. After a few years of wear in a harsh environment, this update also gave the facility a more polished look.

## Renovations

The men's area of the bathroom, including the shower area, urinal wall, doors to the toilet stalls, and adjacent privacy wall were painted with 5L of white oil paint mixed with 7 bottles of green dye. The women's area including the shower and the spaces between the doors of the toilet stalls was painted peach with 5L of white oil paint mixed with 3 bottles of red dye and 2 bottles of yellow dye. The wall surrounding the sinks, and the sink area were painted blue with 5L of white oil paint mixed with 3 bottles of blue dye. The doors to the children's stalls were decorated with red and yellow designs both from 500 mL cans of paint. All paint items were purchased at the Build-It in Franschhoek.





### **Future Recommendations**

Although very difficult to clean, the oil paint was useful because the wood had been previously varnished and also the paint needs to stand up to exposure from weather and constant wear. To help clean the oil paint spilled on the floor, use turpentine and wire brush to remove paint stains.

### **Alphabet and Numbers beneath Sink**

#### **Purpose**

The alphabet and the numbers were painted on the sinks to introduce an educational element to the facility. Additionally, it helped make the facility brighter and more child-friendly.

#### **Renovations**

The alphabet and numbers 1-10 were painted with red and yellow paint, leftover from painting the children's doors. The letters and numbers were hand-drawn in pencil and then painted over and the symbols are approximately 4 inches high.



### **Future Recommendations**

The alphabet and numbers intrigue children who visit the facility and can be used as a teaching tool. We would encourage future projects to work on developing more formal educational activities utilizing such information.

### **Washing Hands Sign above Sink**

#### **Purpose**

The image of two hands washing above the sink and the message “wash your hands every time” in both English and Xhosa serves as a reminder to everyone who uses the facility to wash their hands after using the bathroom. Additionally it provides aesthetic appeal and brightens the atmosphere of the facility.

## Renovations

The image is of two hands being washed sketched in pencil centered above the sinks. It is approximately 1.5'x1.5'. One hand is painted in yellow oil-paint, with plans to paint more, which was not completed before leaving.



## Future Recommendations

This renovation was left incomplete, so ensuring the image is finished with oil paint over the pencil drawing and also adding the words would be highly recommended.

## Posters

### Purpose

The primary purpose of the posters hung around the facility was to create a more educational atmosphere, especially for children who already use the facility. The posters hung in the storage bungalow will help create a more welcoming and educational aftercare space. Additionally, the bright colors and fun graphics provide an aesthetic appeal. Finally, the posters about health and wellbeing reinforce the fundamental ideas behind WaSH-UP.

### Renovations

Four posters were purchased from Osmond's. Two were hung in the facility, one to the left of the sinks above the library bookshelf, one to the right of the sink (figures 1 and 2). Two were hung in the storage bungalow (see figure 3). All posters were hung using tacks on each of the corners. Additional tacks were placed on the sides for increased stability. All tacks needed to be hammered into the walls due to the hardness of the walls behind the posters.





Figure 1: Poster on hygiene habits to the right of the sinks



Figure 2: Poster on South Africa Facts to the left of the sinks



Figure 3: A posters on colors and shapes and a poster on fruit hung in the storage bungalow

### Future Recommendations

There is room for more posters in the storage bungalow to help make the space more appealing and welcoming to children. Additionally, the posters provided many educational opportunities so encouraging educational programmes centered around the different posters would enhance their purpose.

## Recommendations for Future Renovations

### Fencing

#### *Purpose*

A fence could be created both to help define the space for the facility, and prevent uninvited vehicles from parking in the limited outdoor space.

Another mobile fence could be moved in and out of the storage bungalow to help define outdoor space to be used for the aftercare programme. This would create a safe area where children could play and also not be in the way of others who wish to use the facility.

#### *Research/Plans*

Although we made a plan for fencing, we were not able to complete the renovation.

For the permanent fence to mark the space for the facility, we considered creating a tire fence, which could then be painted bright colors to match the rest of the facility. The low height of half-tires (either buried in the ground or cut and placed side-by-side) would clearly mark the area, but not discourage people from coming to the facility.

The fence for the aftercare programme would be a mobile fence so that it could be moved in and out of the facility depending on if the aftercare is open or not. We planned on using cones and rope, which can be easily moved but still clearly designate the area.

### Storage Renovations

#### *Purpose*

The storage bungalow adjacent to the facility is commonly used as a meeting place and also is used for parts of the aftercare programme. It should be rearranged to better organise the various materials and resources there and to create more social space, making sure it is safe for children's use. The social space should also be renovated to make it more suited for "quiet" games, activities, and reading as part of the aftercare programme.

#### *Research/Plans*

Building or adding some sort of shelving or other organising system would help the bungalow remain neat and clean and to create more space within it. Additionally, more educational posters or other brightly colored and child-friendly decorations would be appropriate, as well as the presence of more child-sized tables and chairs. Some have been donated from Nobathembu's crèche, but we are currently unsure of how permanent those are.

### Sign

#### *Purpose*

The sign outside the facility would help to designate the building as a WaSH facility and make it recognizable to general members of the community even from a distance. Additionally, the sign would advertise services offered by the facility such as the aftercare programme, library, kiosk, and hair salon.

### *Research/Plans*

Although several designs for the sign were created, the sign could not be completed. Some considerations for future projects should include material, an overall designer, and design elements. For material, a metal sign will be harder to make than a wooden sign, but is easier to attach firmly to the facility and is less likely to be stolen. A teenage girl from the community, who is a talented artist, had volunteered to help make the sign, although the materials were never purchased so the sign was never completed. The community requested the sign be brightly colored to match the rest of the facility and include lots of pictures.